

Foster

The industry leader in ergonomic material handling solutions for printers, sign makers and manufacturers



NEW

Compact-2 On-A-Roll® Lifter

Reduce on the job Injuries and save time - load rolls directly from the ground to printer with minimal effort.



Easily load rolls onto the fork when flip stops are lowered to the floor.

Flip stops lock in the "up" position for safe transport of rolls.



Improve Safety with the Compact-2 On-a-Roll® Lifter. You can easily load rolls from the floor without having to lift or push the roll over a ramp on the roll tray.

Increase Productivity & Profits

- Single person operation reduces labor cost and saves time.
- Minimize handling damage of expensive roll media.
Save Space & Time
- The compact design occupies less than 4 square feet of floor space. Your Lifter can be stored in the corner when not in use. Great for shops with limited floor space.
- Keep the Lifter right next to your printer and save time transporting rolls.

Important Benefits

- The 49"H lift height is perfect for multiple pieces of equipment in your shop - laminators, calendaring machines and fabric printers.
- 3" high bottom caster frame fits underneath printers with low clearance.
- 1.8"H fork fits between rollers with tight clearances.
- 4 swivel casters help operators maneuver around tight corners, through narrow aisles and sideways through doorways.
- Hydraulic foot pump raises rolls to the exact height required.
- Lift rolls of media as heavy as 330 lbs. (150 kg) and as wide as 96" (244 cm).

Model 61561 Specifications

Maximum Roll Weight	150kgs (330 lbs.)
Maximum Roll Diameter.....	30 cm (12")
Maximum Roll Width.....	244 cm (96")
Maximum Roll Lift Height	130 cm (49")
Height of Flip Stops in "up" Position	17.75 cm (7")
Front Swivel Casters	5 cm (2")
Locking Rear Swivel Casters	12.7 cm (5")
Width x Depth	57 x 65 cm (22.5" x 25.5")
Height.....	158 cm (63.25")
Weight	80 kg (175 lbs.)

To confirm the #61581 is right for your application see drawings with dimensions on page 2.

800-523-4855 or 267-413-6220 fax 267-413-6227

204B Progress Drive, Montgomeryville, PA 18936

Information@go-foster.com

www.go-foster.com

Foster

COMPACT-2 ON-A-ROLL® LIFTER MODEL #61581

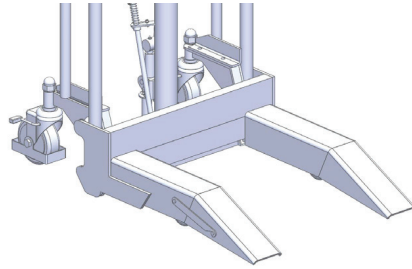
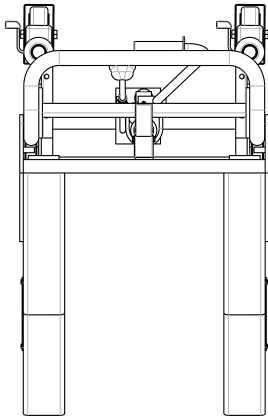

Flip Stops in the Loading Position

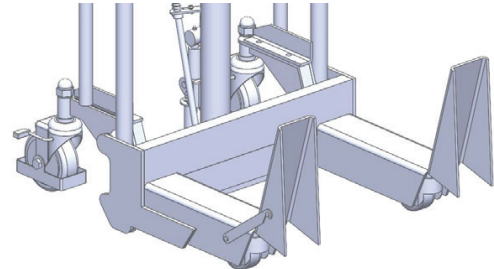

Flip Stops in the Transport Position

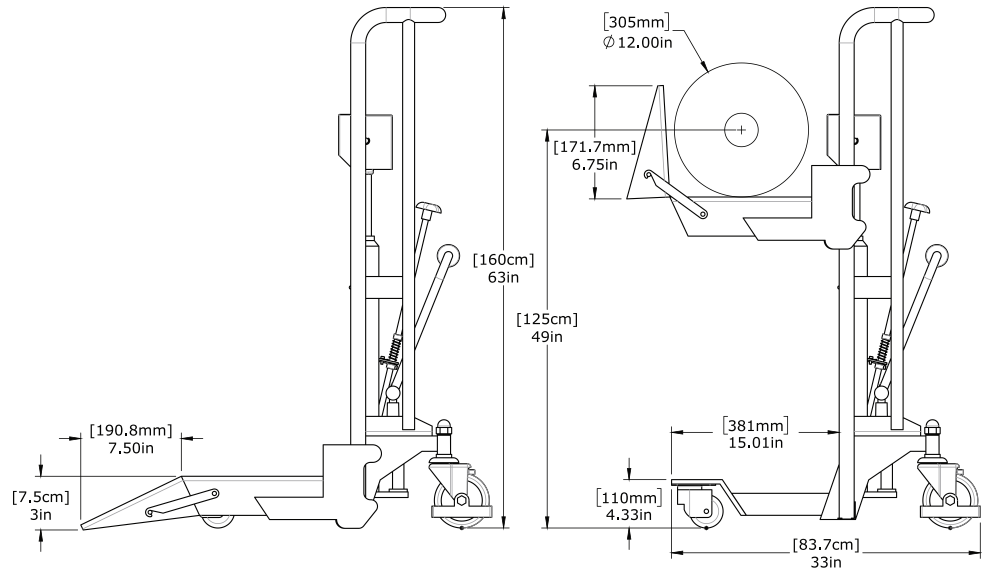
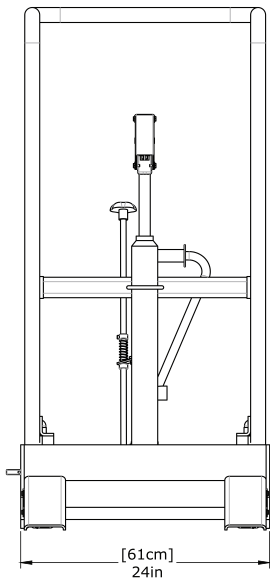

Warranty Box

1-Year Warranty on hydraulic pump
2-Year General Warranty on all parts

The industry leader in ergonomic material handling solutions
for printers, sign makers and manufacturers

800-523-4855 or 267-413-6220 fax 267-413-6227
204B Progress Drive, Montgomeryville, PA 18936

Information@go-foster.com
www.go-foster.com